

Advanced topics on Algorithms

Luciano Gualà

www.mat.uniroma2.it/~guala/

Parameterized algorithms

Episode IV

Toolbox (to show a problem is FPT)

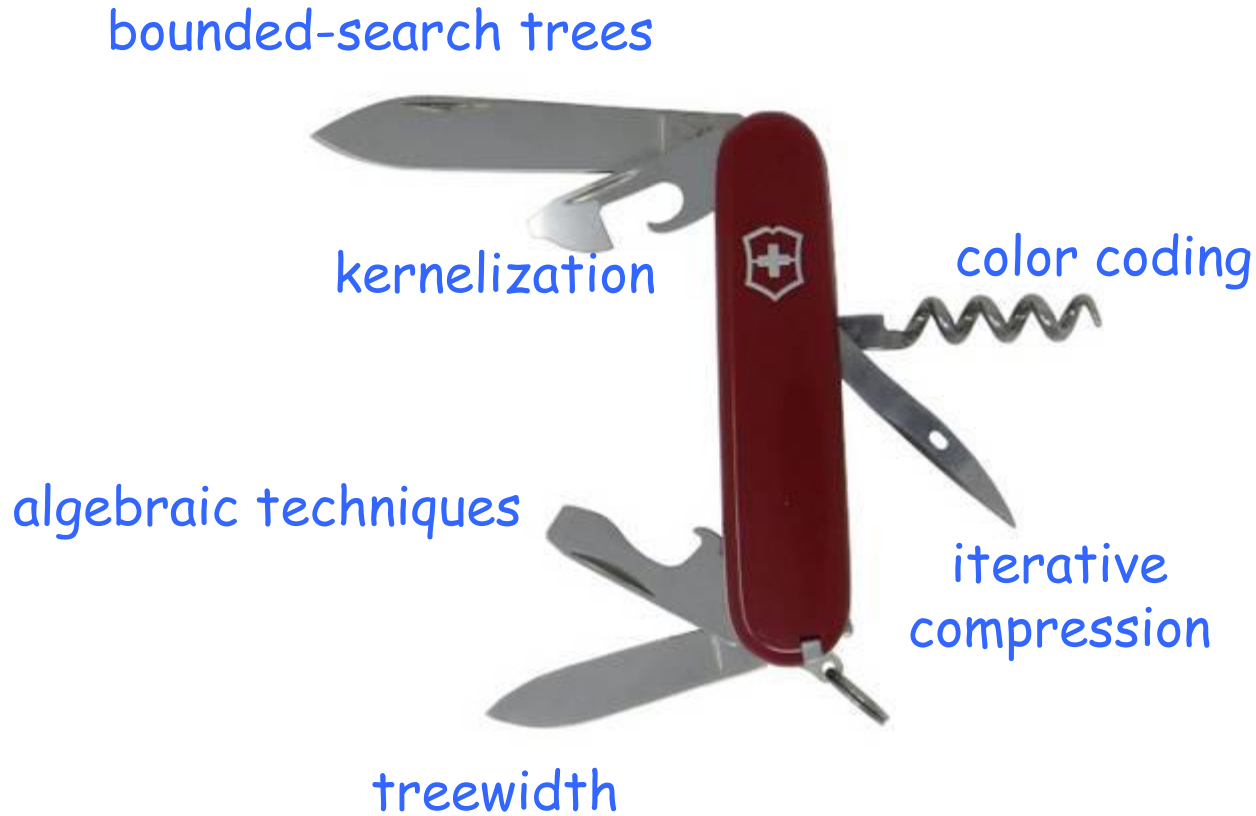

Lower bounds

tools and theory
of the parameterized intractability

What kind of negative results we can prove?

- Can we show that a problem (e.g., **k-Clique**) is not FPT?
- Can we show that a problem (e.g., **k-Vertex Cover**) does not have an algorithm running in time $2^{o(k)}n^{O(1)}$?

obs: we have to assume $P \neq NP$

(if $P=NP$, **k-Clique** can be solved in polynomial time, and hence is FPT)

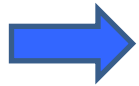

conditional lower bounds

idea: develop a theory that provides evidence that a parameterized problem is hard (e.g., not FPT)

Parameterized complexity

To build a complexity theory for parameterized problems, we need two ingredients:

- An appropriate notion of **reduction**
- An appropriate (hardness) **hypothesis**

obs: Polynomial-time reductions are not good for our purposes

Example: G has an Independent Set of size k iff has a Vertex Cover of size $n-k$

IS problem

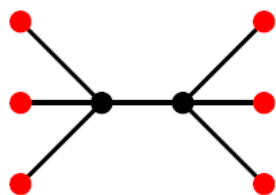

NP-complete

Vertex Cover problem

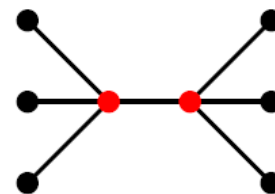

NP-complete

Complexity:



no $n^{o(k)}$ -time
algorithm is known

a $O(2^k n^{O(1)})$
algorithm exists



Parameterized reduction

Parameterized reduction from problem P to problem Q : a function ϕ mapping an instance (x,k) of P into an instance $(x',k') = \phi(x,k)$ of Q , such that

- (x,k) is a YES-instance of P iff (x',k') is a YES-instance of Q ;
- (x',k') can be computed in time $f(k)n^{O(1)}$;
- $k' \leq g(k)$ for some function g .

Note: if Q is FPT then P is also FPT.

Equivalently: if P is not FPT then Q is not FPT.

Non-example: from Independent Set to Vertex Cover

$$(G,k) \quad \longrightarrow \quad (G,n-k)$$

Example: from Independent Set to Clique

$$(G,k) \quad \longrightarrow \quad (\bar{G},k)$$

Multicolored Clique

Input:

- a graph $G=(V,E)$, vertices are colored with k colors
- a nonnegative integer k

question:

is there a clique of size k containing one vertex for each color

parameter: k

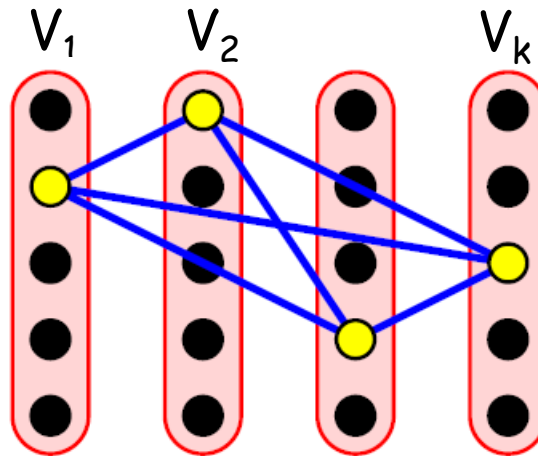

Theorem

There is a parameterized reduction from **Clique** to **Multicolored Clique**.

proof

- for each vertex v of G , G' has k vertices v_1, \dots, v_k , one for each color
- if u and v are adjacent in G , connect all copies of u with all copies of v

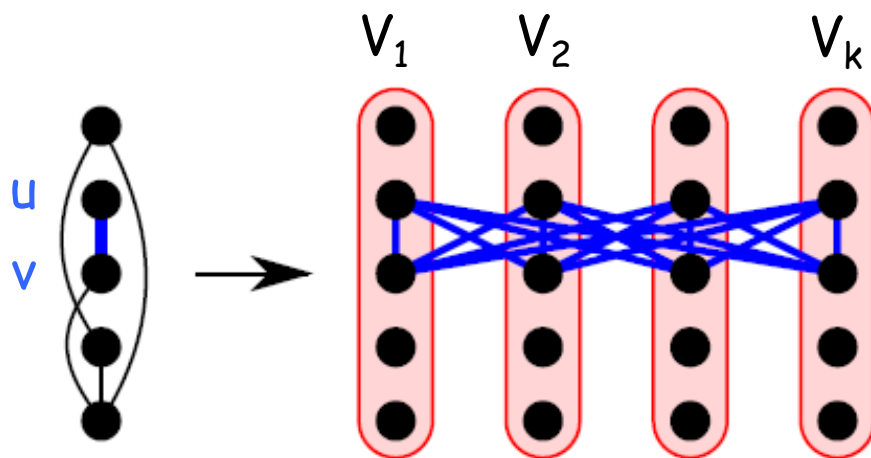

G has a k -clique



G' has a multicolored k -clique

Similarly: reduction from **k -Clique** to **multicolored k -Independent Set**

k-Dominating Set

Input:

- a graph $G=(V,E)$
- a nonnegative integer k

question:

is there a set U of vertices of size $|U| \leq k$ such that each $v \in V \setminus U$ is adjacent to a vertex $u \in U$

parameter: k

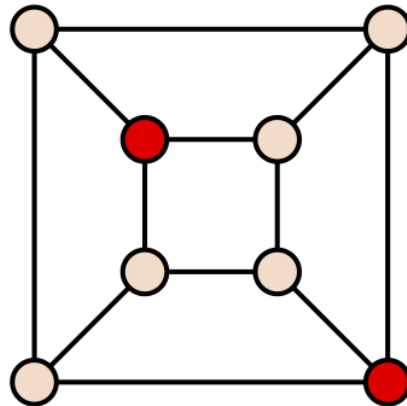

Theorem

There is a parameterized reduction from **Multicolored Independent Set** to **Dominating Set**.

proof

- G' has all vertices of G plus vertices x_i, y_i , for each color i
- for each edge $e=(u,v)$ in G with $u \in V_i$ and $v \in V_j$, add a vertex w_e to G' adjacent to every vertex of $(V_i \cup V_j) \setminus \{u,v\}$

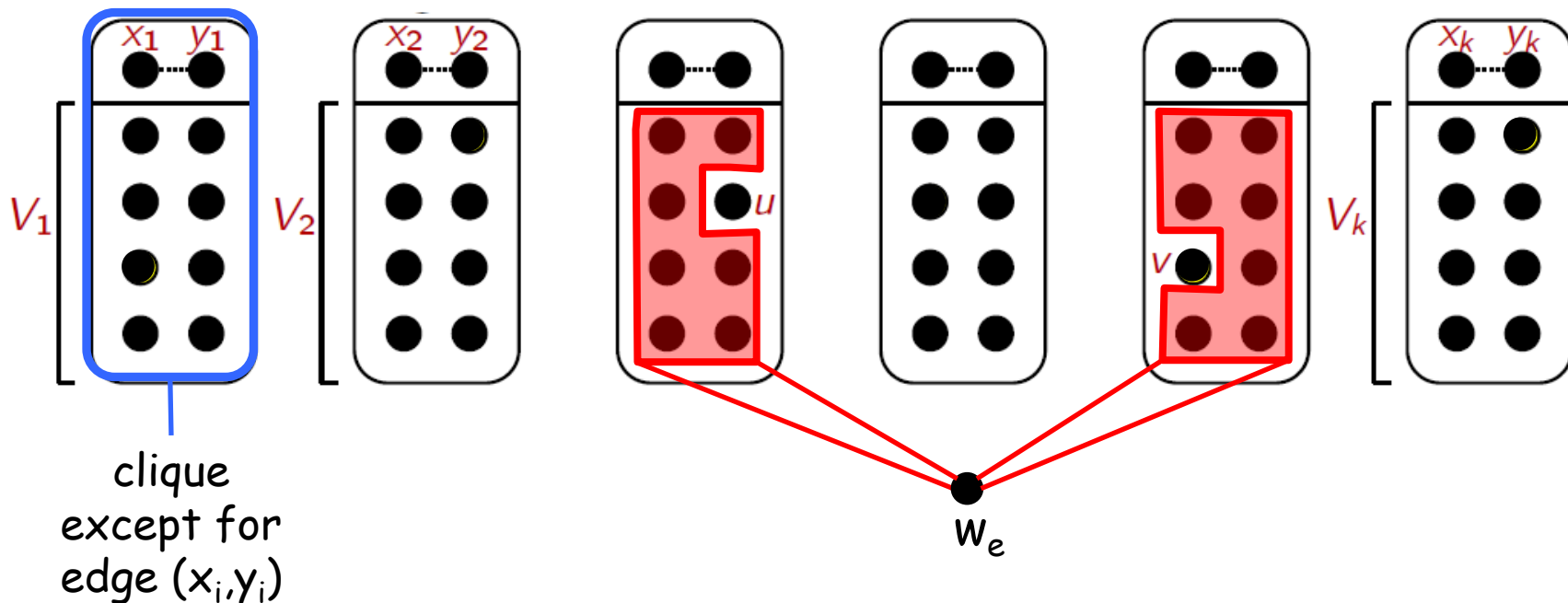

Claim: a k -DS must choose a vertex from each V_i and such vertices must form an independent set in G .

Theorem

There is a parameterized reduction from **Multicolored Independent Set** to **Dominating Set**.

proof

- G' has all vertices of G plus vertices x_i, y_i , for each color i
- for each edge (u,v) in G with $u \in V_i$ and $v \in V_j$, add a vertex w_e to G' adjacent to every vertex of $(V_i \cup V_j) \setminus \{u,v\}$

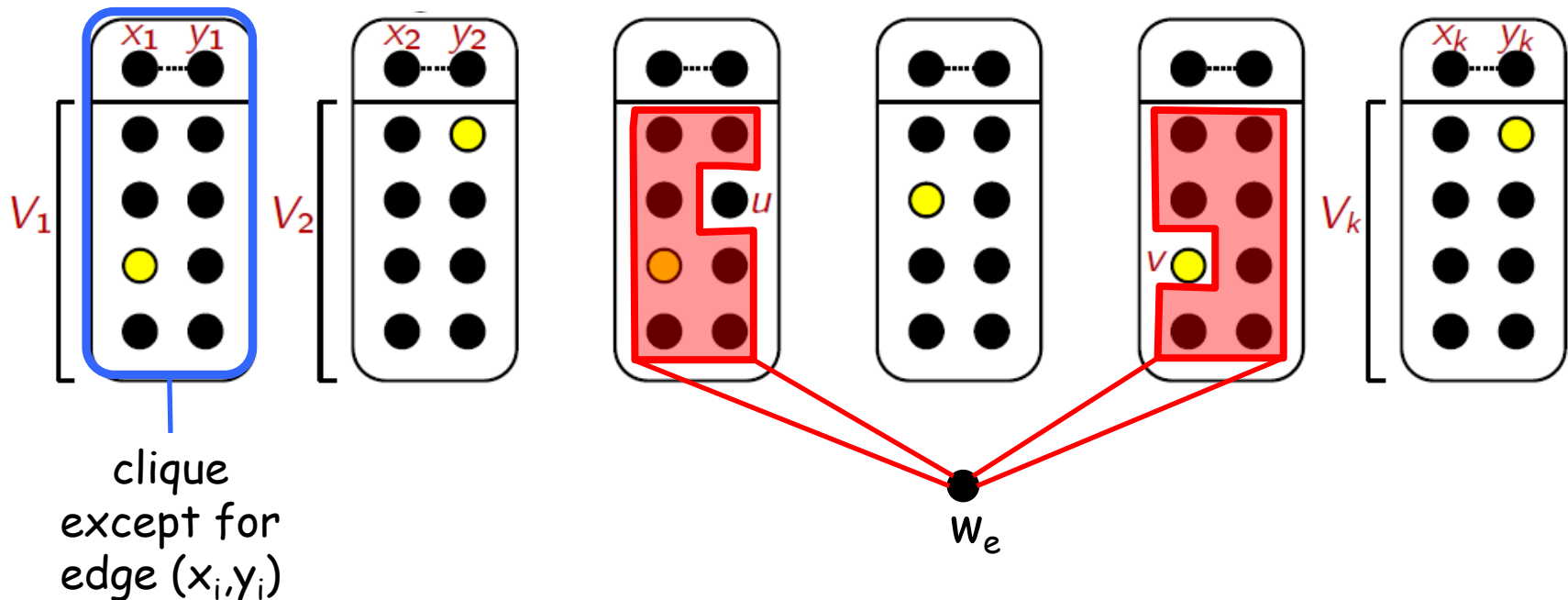

Claim: a k -DS must choose a vertex from each V_i and such vertices must form an independent set in G .

Hard problems

Hundreds of parameterized problems are known to be at least as hard as Clique:

- Independent Set
- Dominating Set (even in bipartite graphs)
- Set Cover
- Hitting Set
- Connected Dominating Set
- Partial Vertex Cover (parameterized by the size of the cover)
- ...

We believe that none of these problems are FPT

Basic Hypothesis

It seems we have to assume something stronger than $P \neq NP$

Let's choose a basic hypothesis:

Engineers' Hypothesis

k -Clique cannot be solved in time $f(k) n^{O(1)}$.



Theorists' Hypothesis

k -Step Halting Problem (is there a path of a given Nondeterministic Turing Machine that stops in k steps?) cannot be solved in time $f(k) n^{O(1)}$.



Exponential Time Hypothesis (ETH)

n -variable 3-SAT cannot be solved in time $2^{o(n)}$.

which hypothesis is most plausible?

Some observations

- k -Clique and k -Step Halting problem can be reduced to each other
 - Engineers' Hypothesis and Theorists' Hypothesis are equivalent!
- k -Clique and k -Step Halting problem can be reduced to k -Dominating Set
- Is there a parameterized reduction from k -Dominating Set to k -Clique?
- Probably not. Unlike in NP-completeness, where most problems are equivalent, here we have a hierarchy of hard problems.
 - Independent Set is $W[1]$ -complete
 - Dominating Set is $W[2]$ -complete
- Does not matter if we only care about whether a problem is FPT or not!

a Boolean circuit consists of input gates, negation gates, AND gates, OR gates, and a single output gate

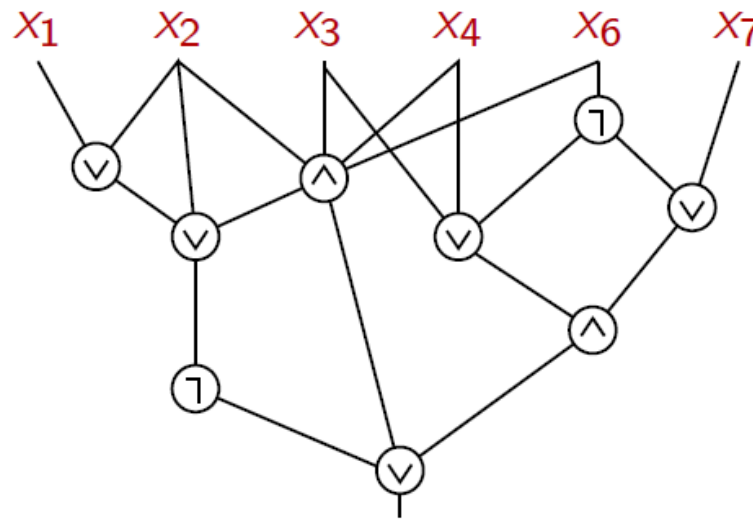

Circuit Satisfiability

Given a Boolean circuit C , decide if there is an assignment on the inputs of C making the output true

weight of an assignment: number of true variables

Weighted Circuit Satisfiability

Given a Boolean circuit C and an integer k , decide if there is an assignment of weight k making the output true

Both k -Independent Set and k -Dominating Set can be reduced to Weighted Circuit Satisfiability

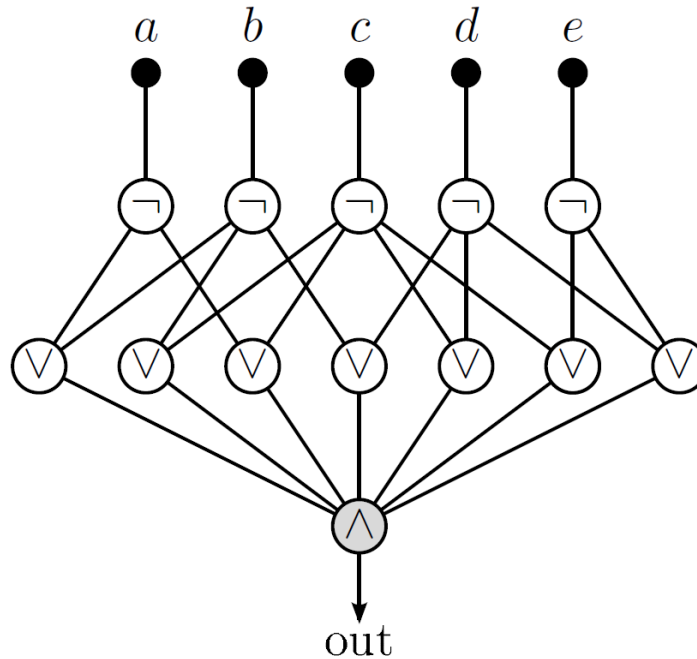
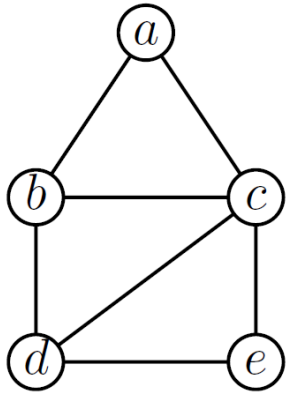

k -Independent Set

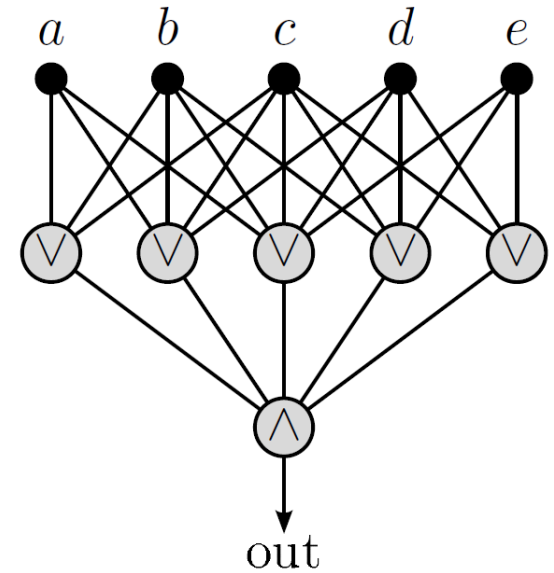

k -Dominating Set

idea: DS is harder than IS because we need a more complicated circuit

depth of a circuit: the maximum length of an input-output path

a gate is **large** if it has more than 2 inputs

weft of a circuit: the maximum number of large gates in an input-output path

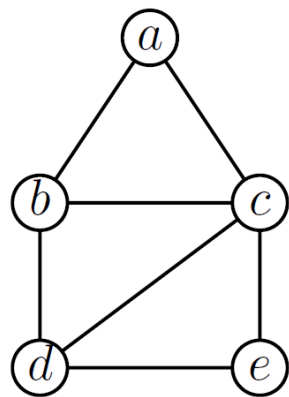

depth: 3 weft: 1

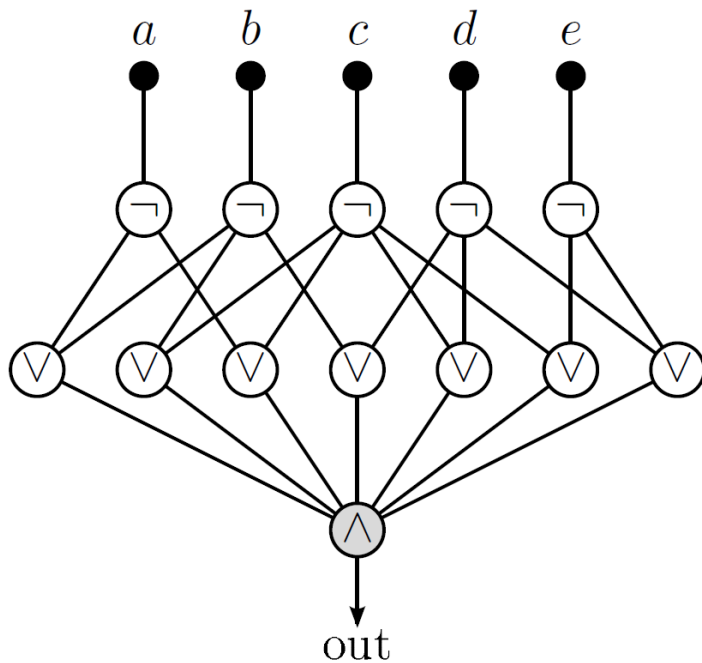

k-Independent Set

depth: 2 weft: 2

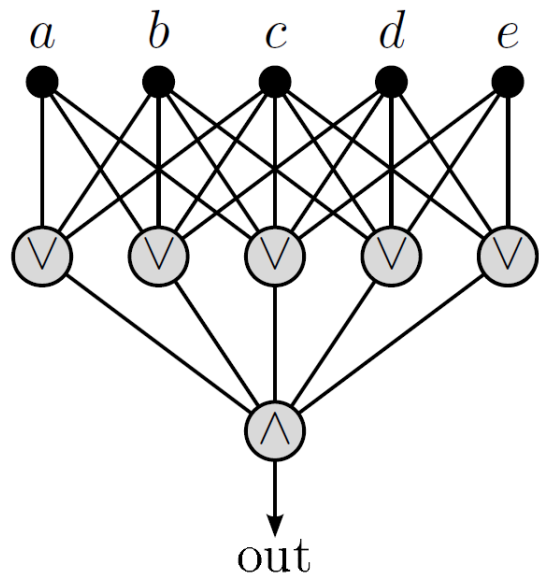

k-Dominating Set

The W-hierarchy

Let $C[t; d]$ be the set of all circuits having weft at most t and depth at most d

Definition

A problem P is in the class $W[t]$ if there is a constant d and a parameterized reduction from P to **Weighted Circuit Satisfiability** of $C[t; d]$

Independent Set is in $W[1]$ and **Dominating Set** is in $W[2]$

fact: Independent Set is $W[1]$ -complete

fact: Dominating Set is $W[2]$ -complete

a problem is **complete** for a given class if every other problem in the class can be reduced to it

 a reduction from DS to IS would imply $W[1]=W[2]$

ETH and some cool
consequences

Exponential Time Hypothesis (ETH)

There is no $2^{o(n)}$ -time algorithm for n -variable 3-SAT

Note: current best algorithm is 1.30704^n [Hertli 2011].

Note: an n -variable 3-SAT formula can have $\Omega(n^3)$ clauses.

Sparsification lemma [Impagliazzo, Paturi, Zane 2001]

There is no $2^{o(n)}$ -time algorithm for n -variable 3-SAT



There is no $2^{o(m)}$ -time algorithm for m -clause 3-SAT

Transferring lower bounds: an example

Exponential Time Hypothesis (ETH)

There is no $2^{o(m)}$ -time algorithm for m -clause 3-SAT

The textbook reduction from 3-SAT to 3-Coloring:

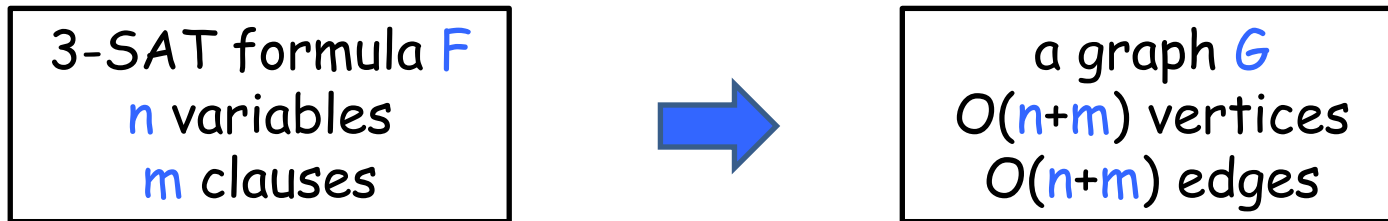

Transferring lower bounds: an example

Exponential Time Hypothesis (ETH)

There is no $2^{o(m)}$ -time algorithm for m -clause 3-SAT

The textbook reduction from 3-SAT to 3-Coloring:

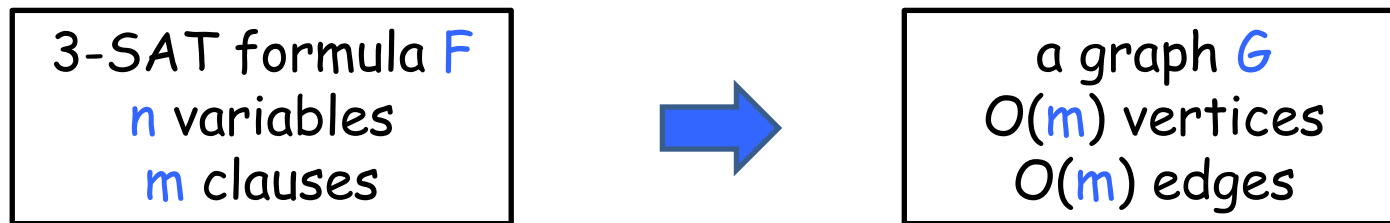

Corollary

Assuming ETH, there is no $2^{o(n)}$ -time algorithm for 3-coloring on an n -vertex graph

Transferring lower bounds

There are many similar reductions from **3-SAT** to other graph problems.

Consequence:

Assuming ETH, there is no $2^{o(n)}$ -time algorithm on an n -vertex graph for:

- Independent Set
- Clique
- Dominating Set
- Vertex Cover
- Longest Path
- ...

Transferring lower bounds

There are many similar reductions from 3-SAT to other graph problems.

Consequence on the $f(k)$ game:

Consequence:

Assuming ETH, there is no $2^{o(k)}n^{o(1)}$ time algorithm on an n -vertex graph for:

- k -Independent Set
 - k -Clique
 - k -Dominating Set
 - k -Vertex Cover
 - k -Path
 - ...
- } roughly tight since they
can be solved in time
 $2^{O(k)}n^{O(1)}$

Engineers' Hypothesis

k-Clique cannot be solved in time $f(k) n^{O(1)}$.



Theorists' Hypothesis

k-Step Halting Problem (is there a path of a give Nondeterministic Turing Machine that stops in k steps?) cannot be solved in time $f(k) n^{O(1)}$.



Exponential Time Hypothesis (ETH)

n-variable 3-SAT cannot be solved in time $2^{o(n)}$.

Assuming ETH we can prove that k-Clique is not FPT.

Indeed, we can prove a much stronger and interesting result:

Theorem [Chen et al. 2004]

k-Clique cannot be solved in time $f(k) n^{o(k)}$ for any computable function f

proof

assume you can find a k -clique on a graph H in time $f(k) |V(H)|^{k/s(k)}$,
 $s(k)$: (positive) nondecreasing unbounded function

we show you can find a 3-coloring of G in $2^{o(n)}$ time (contradicting ETH)

technical assumption:

$$f(k) \geq \max\{k, k^{k/s(1)}\} \quad \text{otherwise set } f'(k) = \max\{f(k), k, k^{k/s(1)}\}$$

partition the n vertices of G into k groups of at most $\lceil n/k \rceil$ vertices each

build H as follows:

- each vertex corresponds to a proper 3-coloring of one of the groups
- two vertices of H are connected iff the corresponding colorings are compatible

$$|V(H)| \leq k 3^{\lceil n/k \rceil}$$

Claim: there is a k -clique in H iff G admits a proper 3-coloring

now, we suitably choose k ...

for a given n , let k be the largest integer such that $f(k) \leq n$

$k := g(n)$ nondecreasing unbounded function on n (satisfying $g(n) \leq n$)

time to compute a 3-coloring of G :

$$\begin{aligned} f(k) |V(H)|^{k/s(k)} &\leq f(k) \left[k 3^{\lceil n/k \rceil} \right]^{k/s(k)} && \text{using } f(k) \leq n \\ &\leq n \left[k 3^{\lceil n/k \rceil} \right]^{k/s(k)} && \text{using } k = g(n) \leq n \\ &\leq n \left[k 3^{2n/k} \right]^{k/s(k)} && \text{using } s(k) \text{ nondecreasing} \\ &\leq n k^{k/s(1)} 3^{2n/s(k)} && \text{using } k^{k/s(1)} \leq f(k) \leq n \\ &\leq n^2 3^{2n/s(g(n))} && \text{function } s(g(n)) \text{ is} \\ &= 2^{o(n)} && \text{nondecreasing \& unbounded} \end{aligned}$$



Strong ETH

k-Dominating Set

Input:

- a graph $G=(V,E)$
- a nonnegative integer k

question:

is there a set U of vertices of size $|U| \leq k$ such that each $v \in V \setminus U$ is adjacent to a vertex $u \in U$

parameter: k

naive: n^{k+1}

$n^{k/10}$?

smarter: $n^{k+o(1)}$

n^{k-1} ?

assuming ETH: no $f(k) n^{o(k)}$

Exponential Time Hypothesis (ETH)

There is no $2^{o(n)}$ -time algorithm for n -variable 3-SAT

Note: current best algorithm is 1.30704^n [Hertli 2011].

Strong ETH (SETH)

There is no $(2-\varepsilon)^n$ -time algorithm for CNF-SAT

for any fixed k , a $n^{k-0.01}$ time algorithm for k -DS would violate SETH

assuming SETH:

no $n^{2.99}$ time algorithm for 3-DS

no $n^{3.99}$ time algorithm for 4-DS

no $n^{4.99}$ time algorithm for 5-DS

...